

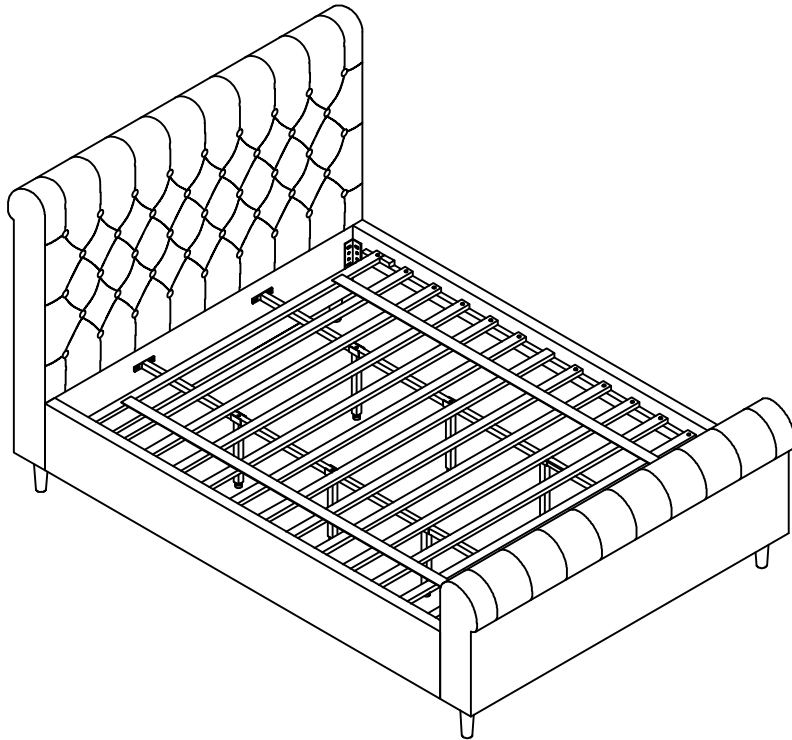

















ASSEMBLY INSTRUCTION

Item No:Y9283 K



Do not tighten bolts until completely assembled.

PARTS IDENTIFICATION			
NO	Part	Sketch	Quantity
#1		Headboard	1PC
#2		Footboard	1PC
#3		Side Rail	2PCS
#4		Center Bar	2PCS
#5		Slats For Daybed	1PC
#6		LEGS	4PCS

HARDWARE LIST			
NO	Shape	Specification	Quantity
A		Allen Wrench 5mm	1PC
B		Allen Wrench 4mm	1PC
C		Bolt 5/16"x2"	10PCS
D		Bolt 5/16"x1-1/4"	20PCS
E		Bolt 1/4"x1"	16PCS
F		Lock Washer 5/16"	24PCS
G		Flat Washer 5/16"x22MM	30PCS
H		Flat Washer 1/4"x16MM	16PCS
I		Screw M8*1-1/4"	30PCS
J		Screw M10*1-1/2"	16PCS
K		Supporting foot	6PCS
L		CONNECTION STRAP	4PCS

STEP:1

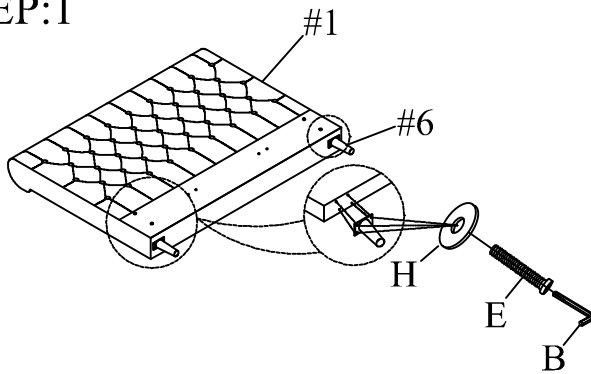

STEP:2

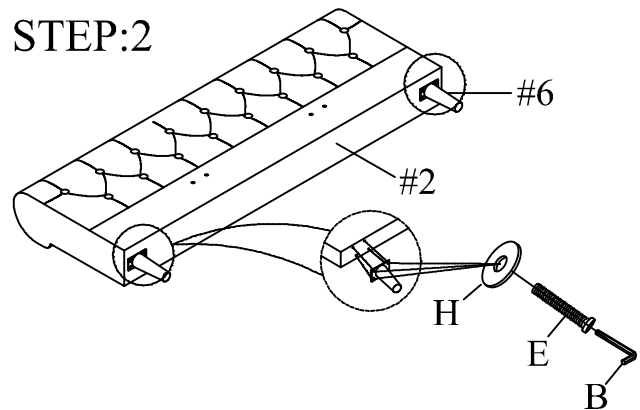

STEP:3

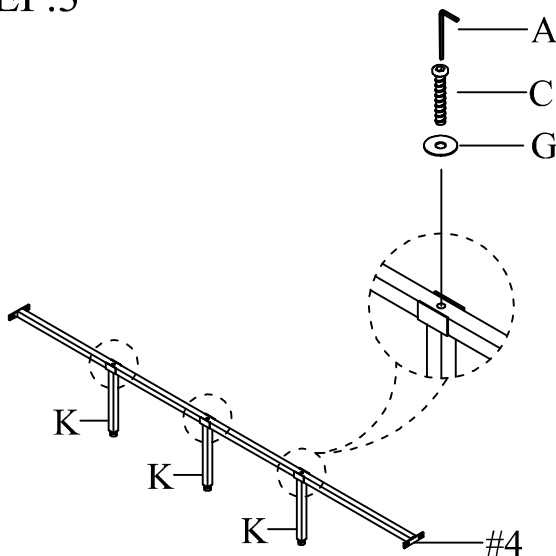

STEP:4

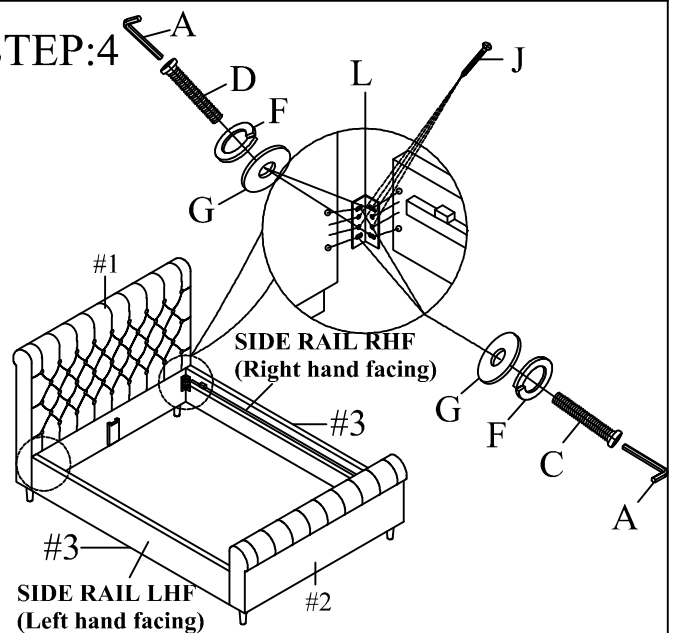

STEP:5

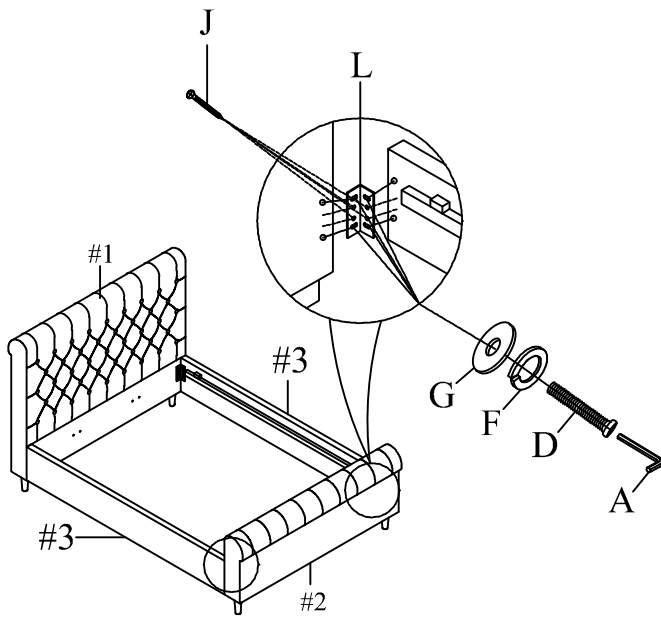

STEP:6

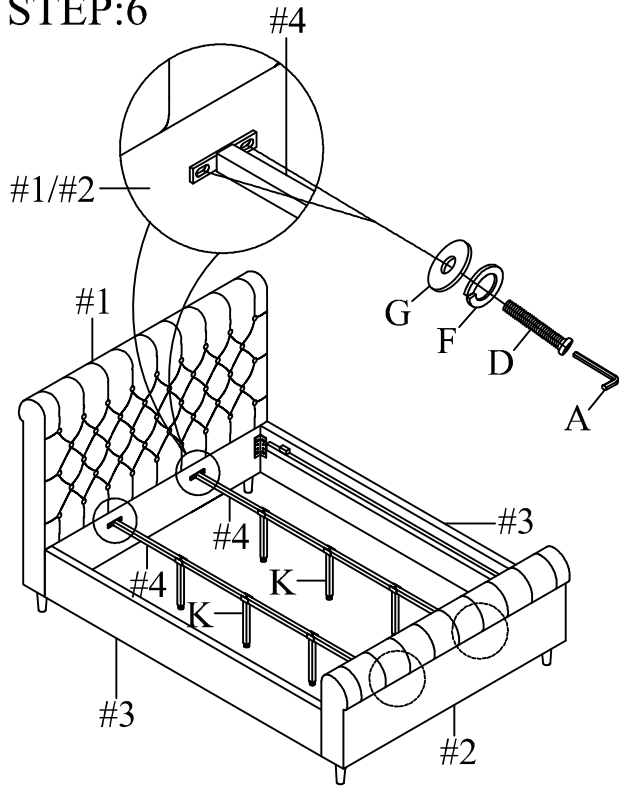

STEP:7

