

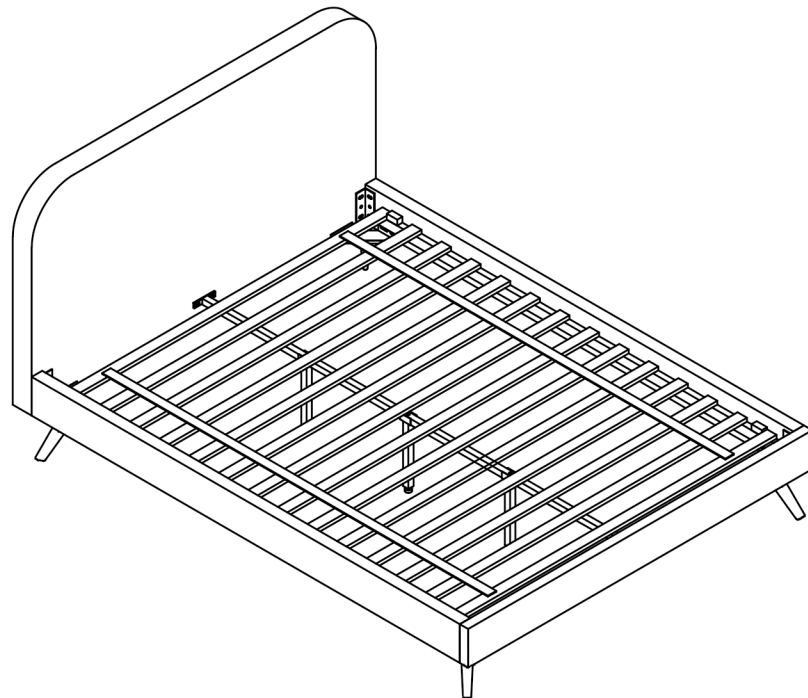















# ASSEMBLY INSTRUCTION

**Item No:** ASH3062 F/D ALICE



**Do not tighten bolts until completely assembled.**

PARTS IDENTIFICATION			
NO	Part	Sketch	Quantity
#1		Headboard	1PC
#2		Footboard	1PC
#3		Side Rail	2PCS
#4		Center Bar 1946mm	1PC
#5		Slats For Daybed	1PC
#6		LEG 160mm	4PCS

HARDWARE LIST			
NO	Shape	Specification	Quantity
A		Allen Wrench 5mm	1PC
B		Bolt 5/16"x2"	3PCS
C		Bolt 5/16"x1-1/4"	36PCS
D		Lock Washer 5/16"	36PCS
E		Flat Washer 5/16"x22MM	39PCS
F		Screw M8*1-1/4"	30PCS
G		Screw M10*1-1/2"	8PCS
H		Supporting foot 225mm	3PCS
I		CONNECTION STRAP 130mm	4PCS

### STEP:1

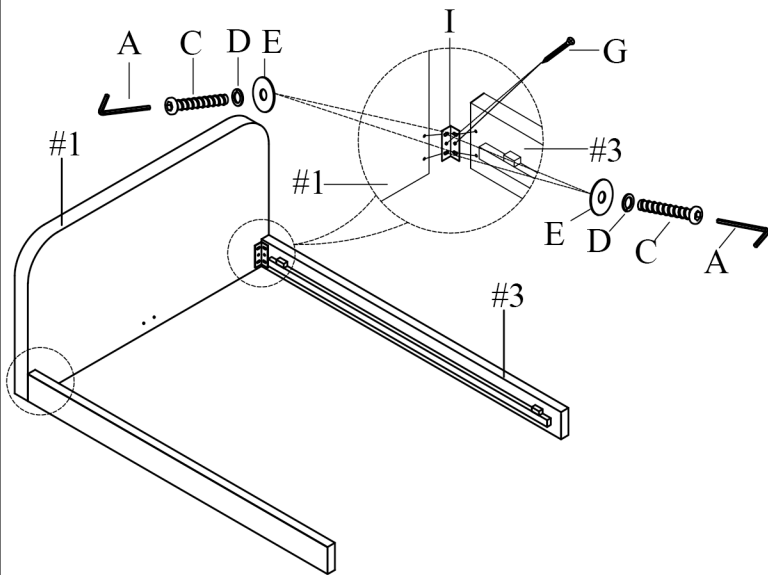

### STEP:2

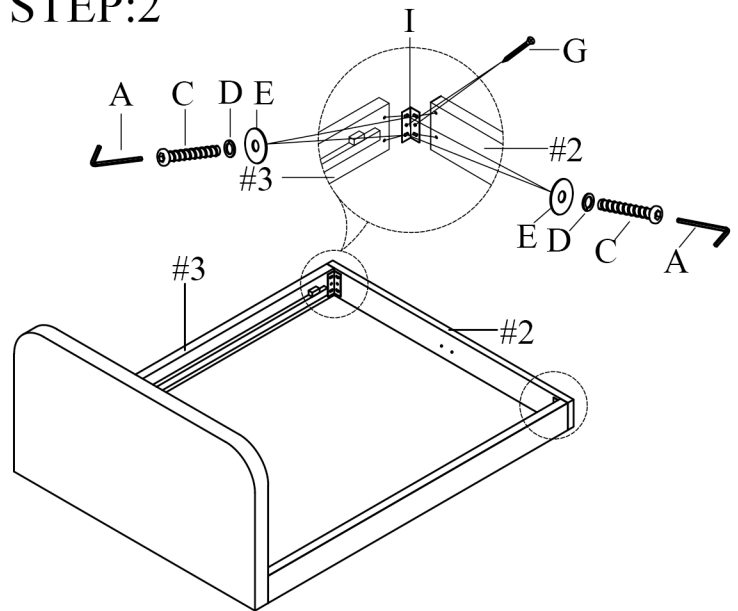

### STEP:3

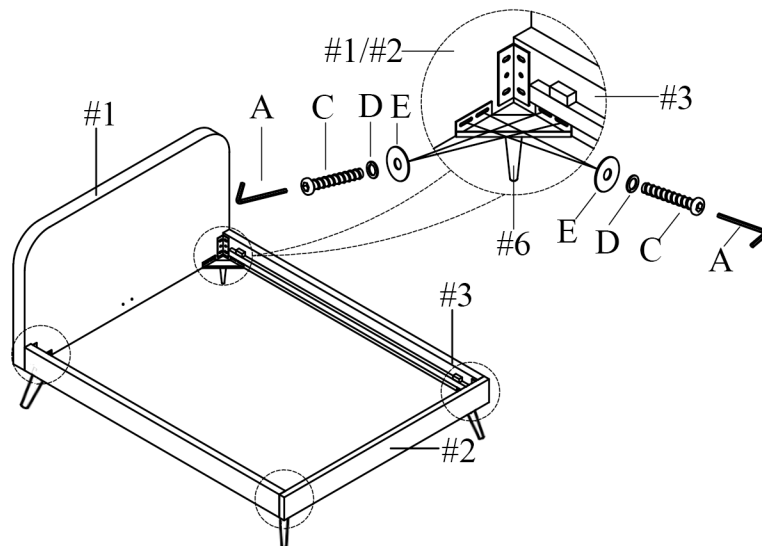

### STEP:5

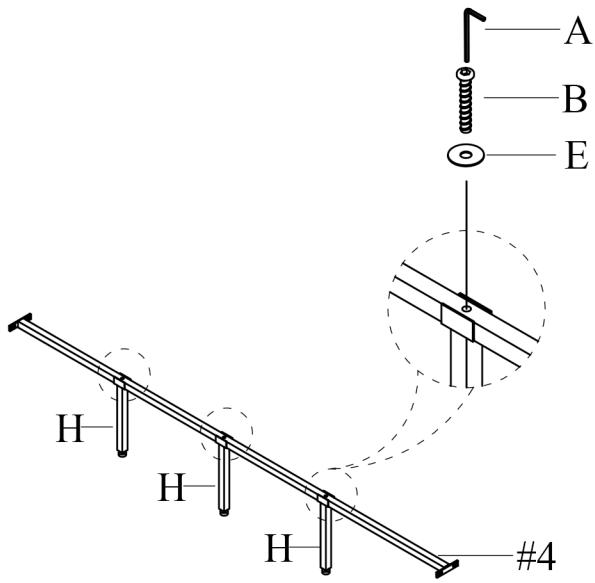

### STEP:6

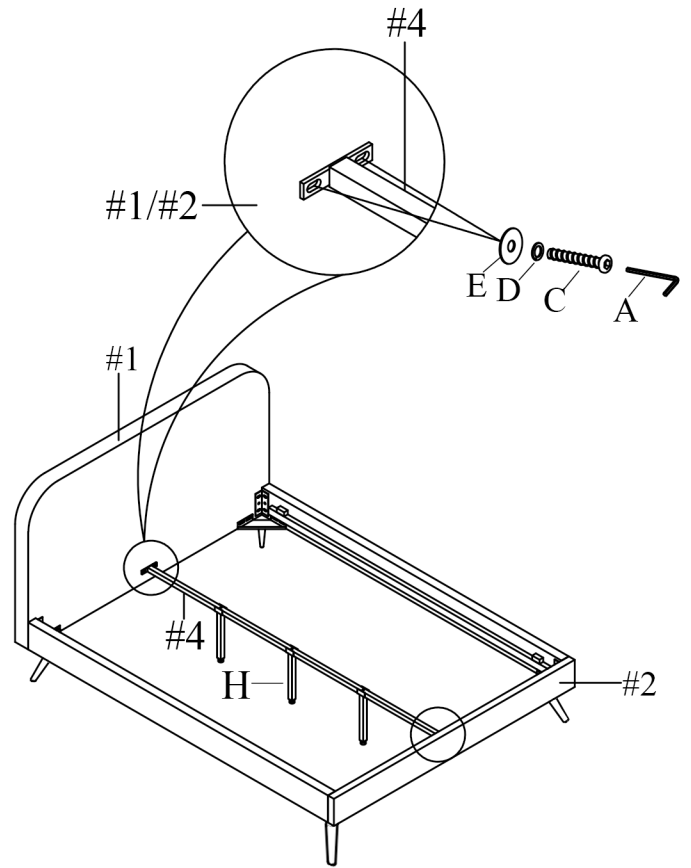

### STEP:7

